

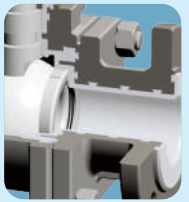

Kingdom

FLOW CONTROL CO., LTD.



Lined
Ball Valves

Product features

The fluorine lined ball valve is made with specially crafted molds to ensure a delicate surface for perfect sealing. The V-shaped PTFE or TFM1600 stem packing assembly assures zero leakage of valves. Full fluorine plastic lining technology is applied for strong corrosive mediums.

Both the inner chamber and the ball are made using high-pressure injection molding with corrosion-resistant and ageing-resistant PFA lining for reliable anti-corrosion and sealing performance. The fluorine lined ball valve is suitable for use by the petrochemical, chemical engineering, food processing, and pharmaceutical industries to block strongly corrosive mediums, such as acid and alkaline, in the production process.

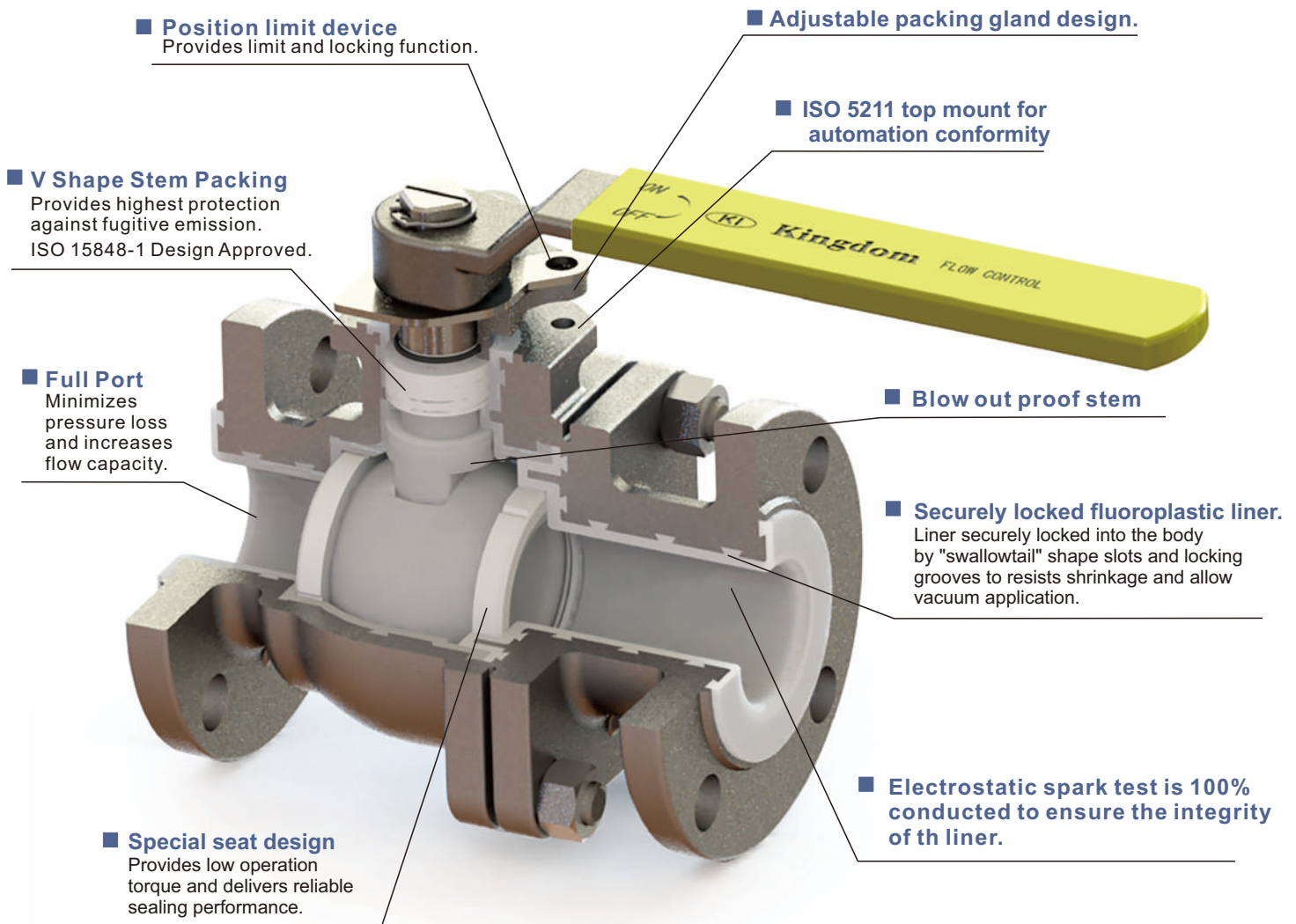

Applicability in Process Control



Petrochemical



Chemical

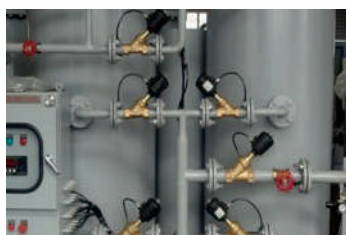

Food



Pharmaceutical

Material of Construction

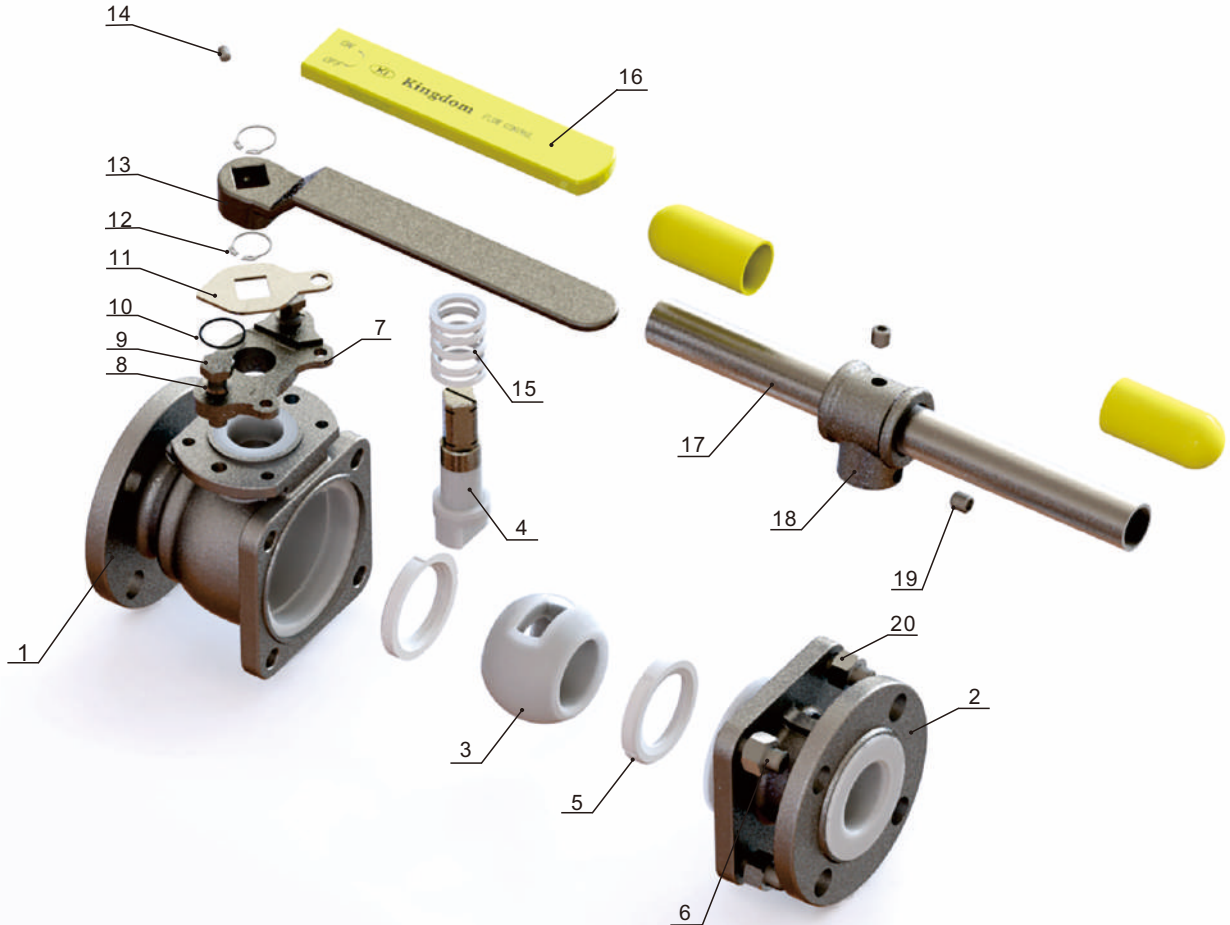

NO.	PART	MATERIAL		
1	Body	1.4408/CF8M+PFA	1.4308/CF8+PFA	1.0619/WCB+PFA
2	End Cap	1.4408/CF8M+PFA	1.4308/CF8+PFA	1.0619/WCB+PFA
3	Ball	1.4408/CF8M+PFA*	1.4308/CF8 /+PFA*	
4	Stem	316 +PFA	304+PFA	
5	Ball Seat	PTFE / TFM1600		
6	Bolting	A193-B8/A2-70		A193-B7/8.8
7	Gland	CF8		
8	Flat Washer	304		
9	Hex Bolting	A2-70		
10	O-Ring	FKM		
11	Triangle Stopper	304		
12	Snap Ring	304		
13	Handle (NPS ½~2)	CF8		
14	Binding Screw (NPS ½~2)	A2-70		
15	Stem Packing	PTFE / TFM1600		
16	Handle Sleeve	VINYL PLASTIC		
17	Steel Pipe (NPS 2½~4)	A53+PLATED Zn		
18	Handle Adapter (NPS 2½~4)	CF8		
19	Binding Screw (NPS 2½~4)	A2-70		
20	Bolt Nut	A194-8/A2-70	A194-2H/8	

AVAILABILITY	
Pressure Rating	ASME Class 150 DIN PN16
Temperature Range	-29°C ~ +160°C
Size Range	½"~4" / DN15~DN100

APPLICATION
Good performance for corrosive media mainly in :
Acetic Acid
Brine
Bromine
Chlorine
Hydrochloric Acid
Phosphoric Acid
Nitric Acid
Seawater
Sulfuric Acid

- Design Standard : EN12516-1
- Pressure Rating : PN16
- Wall Thickness : EN12516-1
- Face to Face : EN558 series1
- Flanged Ends : EN1092-1
- Inspection & Testing : EN12266-1
- ISO 15848-1 Design Approved

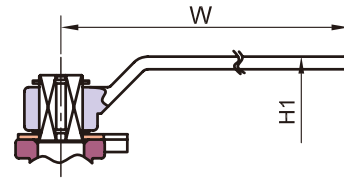

DN15 ~ DN50

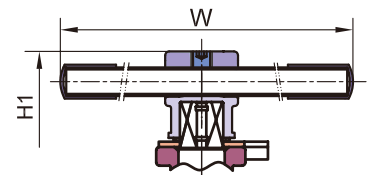

DN65 ~ DN100

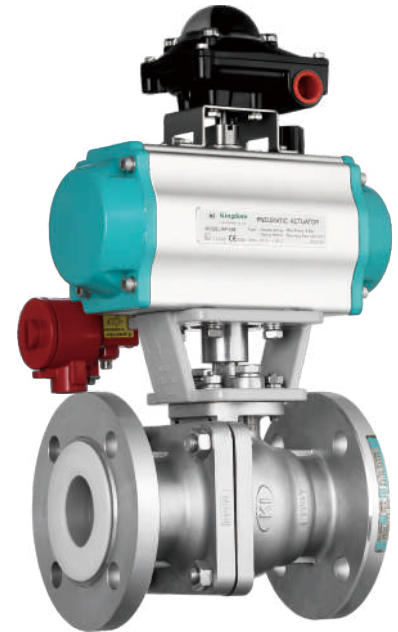
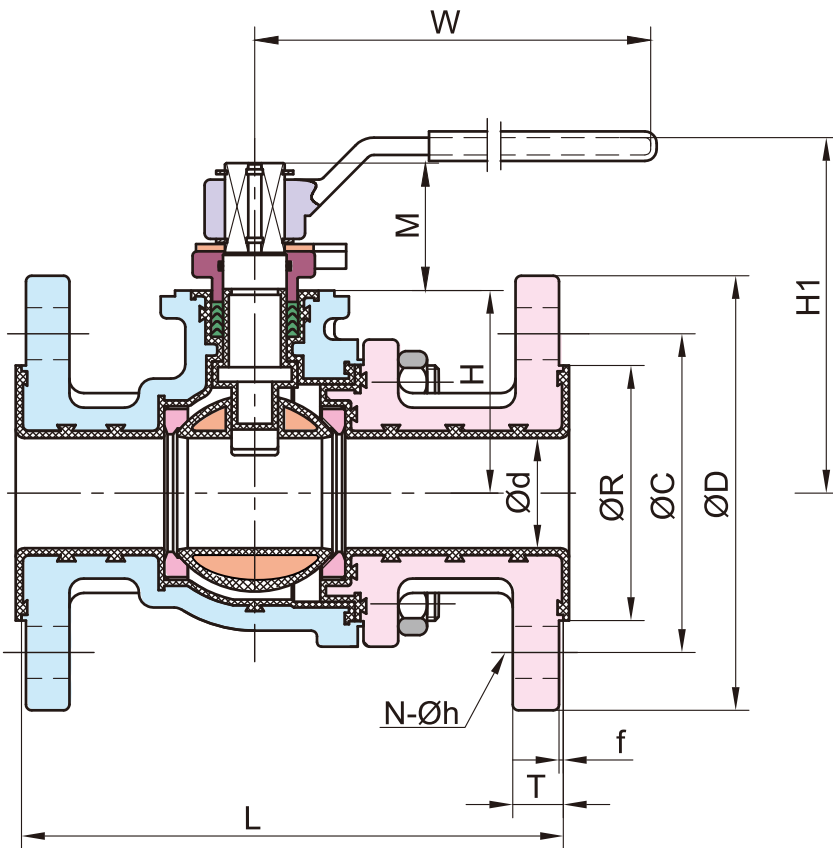
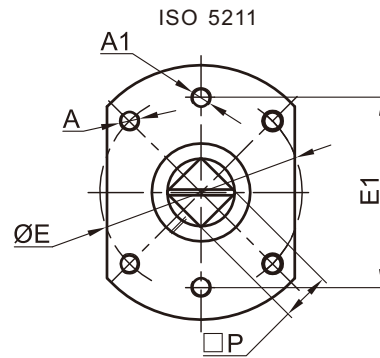
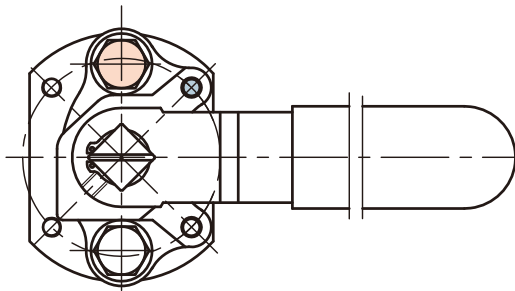

■ EN PN16

Unit:mm

DN	d	R	C	D	L	T	f	N	h	H	H1	M	W	P	E	E1	A	A1	ISO5211
15	15	45	65	95	130	16	2	4	14	39	81.5	20	130	9	42	42	M5	M8	F04
20	20	58	75	105	150	18	2	4	14	46	92	26.5	140	11	50	50	M6	M8	F05
25	25	68	85	115	160	18	2	4	14	48	96.5	29	170	14	50	50	M6	M8	F05
32	32	78	100	140	180	18	2	4	18	55.5	103.5	29	170	14	50	50	M6	M8	F05
40	38	88	110	150	200	18	3	4	18	70	123	44	230	17	70	66	M8	M10	F07
50	50	102	125	165	230	18	3	4	18	76	129	44	230	17	70	66	M8	M10	F07
65	64	122	145	185	290	18	3	8	18	104	191	45.5	300	17	102	75	M10	M12	F10
80	76	138	160	200	310	20	3	8	18	119	215	50.5	400	22	102	75	M10	M12	F10
100	100	158	180	220	350	20	3	8	18	136	230	51	400	27	102	102	M10	M12	F10

- Design Standard: ASME B16.34
- Pressure Rating: Class 150
- Wall Thickness: ASME B16.34
- Face to Face: ASME B16.10
- Flanged Ends: ASME B16.5
- Inspection & Testing: API 598
- ISO 15848-1 Design Approved

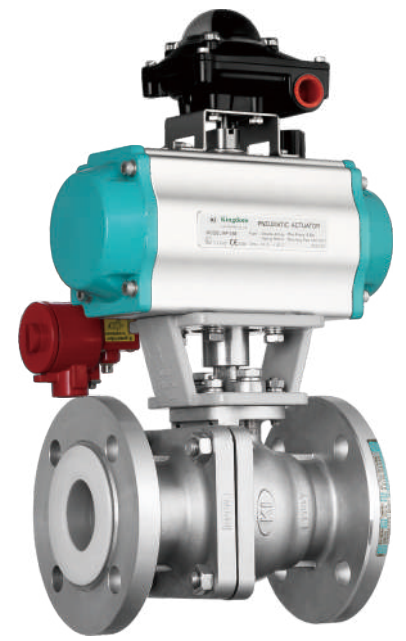
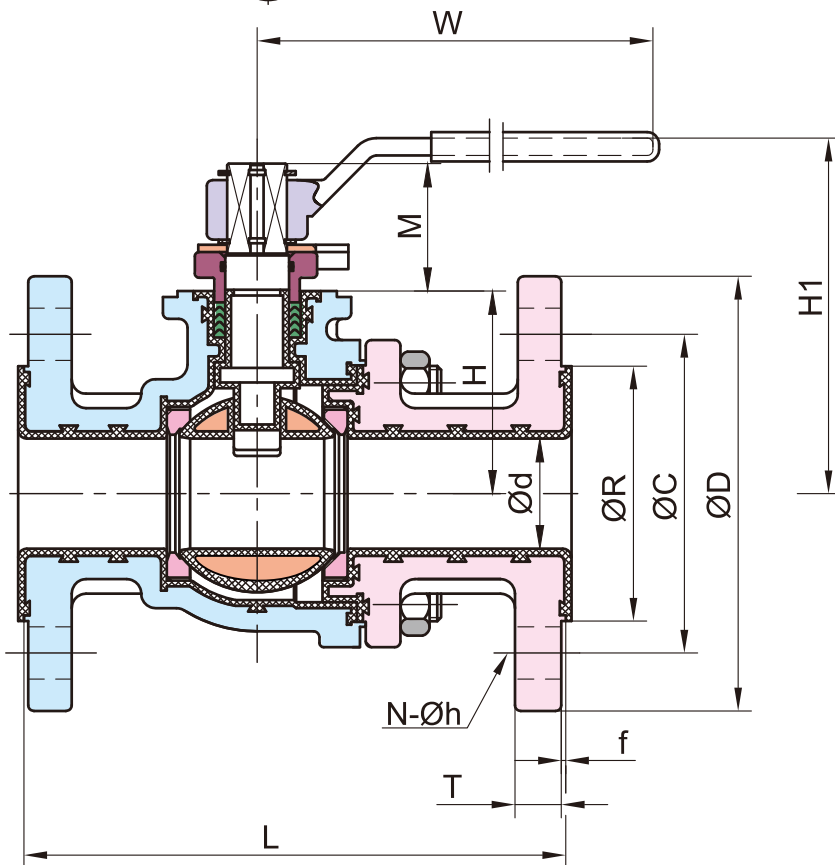
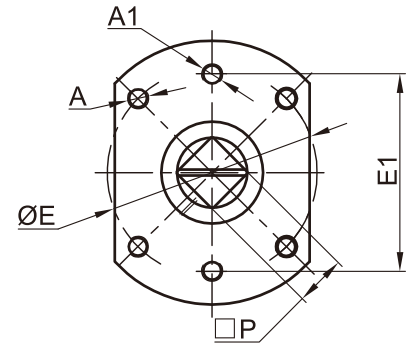
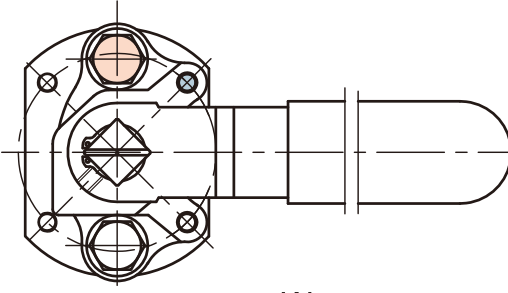
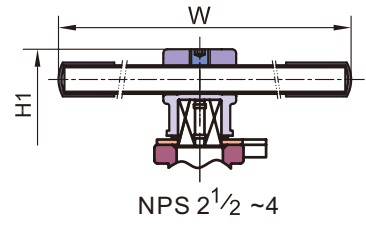
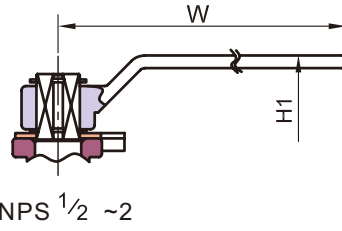

■ ASME Class 150

Unit:mm

NPS	d	L	R	C	D	f	T	N	h	H	H1	M	W	P	A	A1	E	E1	ISO5211
1/2	15	108	34.9	60.3	90	2	8	4	1/2-13UNC	39	81.5	20	130	9	M5	M8	42	42	F04
3/4	20	117	42.9	69.9	100	2	8.9	4	1/2-13UNC	46	92	26.5	140	11	M6	M8	50	50	F05
1	25	127	50.8	79.4	110	2	9.6	4	16	48	96.5	29	170	14	M6	M8	50	50	F05
1 1/4	32	140	63.5	88.9	115	2	11.2	4	16	55.5	103.5	29	170	14	M6	M8	50	50	F05
1 1/2	38	165	73.0	98.4	125	2	12.7	4	16	70	123	44	230	17	M8	M10	70	66	F07
2	50	178	92.1	120.7	150	2	14.3	4	19	76	129	44	230	17	M8	M10	70	66	F07
2 1/2	65	190	104.8	139.7	180	2	15.9	4	19	104	191	45.5	300	17	M10	M12	102	75	F10
3	76	203	127.0	152.4	190	2	17.5	4	19	119	215	50.5	400	22	M10	M12	102	75	F10
4	100	229	157.2	190.5	230	2	22.3	8	19	136	230	51	400	27	M10	M12	102	102	F10

Product features

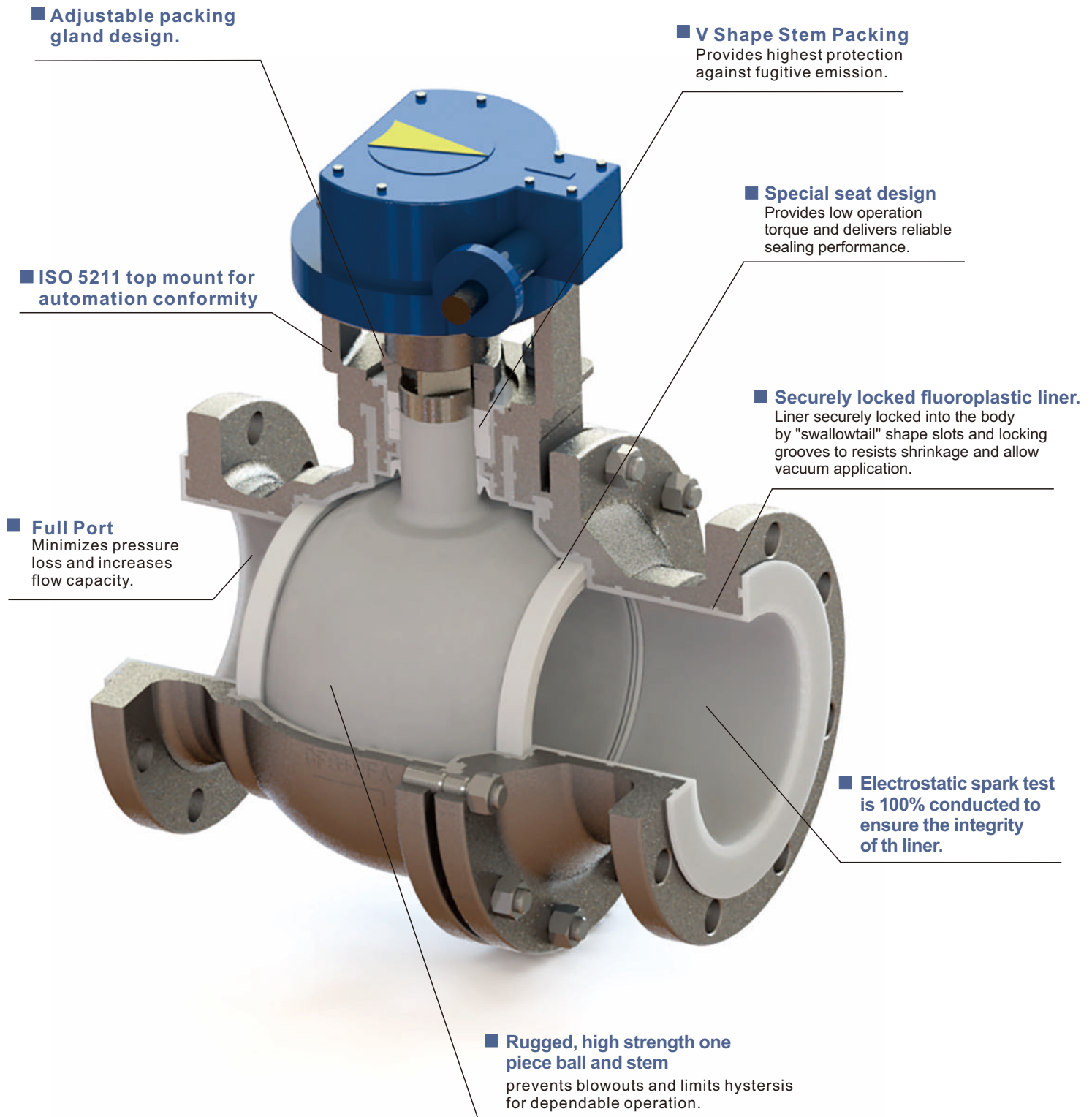

Material of Construction

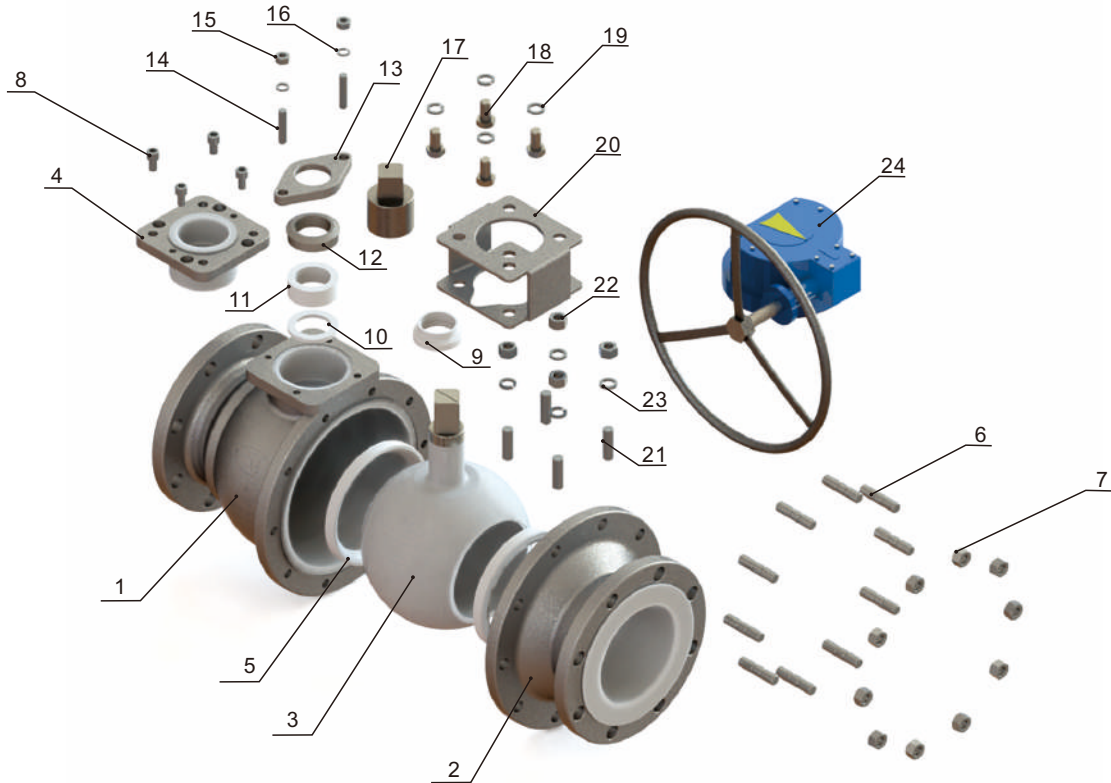

NO.	PART	MATERIAL		
1	Body	1.4408/CF8M+PFA	1.4308/CF8+PFA	1.0619/WCB+PFA
2	End Cap	1.4408/CF8M+PFA	1.4308/CF8+PFA	1.0619/WCB+PFA
3	Ball	1.4408/CF8M+PFA	1.4308/CF8 /+PFA	
4	Mid Flange	1.4408/CF8M+PFA	1.4308/CF8+PFA	1.0619/WCB+PFA
5	Ball Seat	PTFE / TFM1600		
6	Bolting	A193-B8/A2-70		A193-B7/8.8
7	Bolt Net	A194-8/A2-70		A194-2H/8
8	Screw	A2-70		8.8
9	Thrust Washer	PTFE / TFM1600		
10	Packing Gasket	PTFE / TFM1600		
11	Packing	PTFE / TFM1600		
12	Gland	CF8		
13	Gland Pressure Plate	CF8		
14	Bolting	A193-B8/A2-70		A193-B7/8.8
15	Bolt Net	A194-8/A2-70		A194-2H/8
16	Flat Washer	304		
17	Extended Stem	316	304	
18	Hex Bolting	A2-70		8.8
19	Flat Washer	304		
20	Bracket	CF8		
21	Bolting	A193-B8/A2-70		A193-B7/8.8
22	Bolt Net	A194-8/A2-70		A194-2H/8
23	Flat Washer	304		
24	Worm Gear	Assembly		

AVAILABILITY	
Pressure Rating	ASME Class 150
	DIN PN16
Temperature Range	-29°C ~ +160°C
Size Range	5"~6" / DN125~DN150

APPLICATION
Good performance for corrosive media mainly in :
Acetic Acid
Brine
Bromine
Chlorine
Hydrochloric Acid
Phosphoric Acid
Nitric Acid
Seawater
Sulfuric Acid

KV-N84K

- Design Standard : EN12516-1
- Pressure Rating : PN16
- Wall Thickness : EN12516-1
- Face to Face : EN558 series12
- Flanged Ends : EN1092-1
- Inspection & Testing : EN12266-1

KV-N841

- Design Standard : ASME B16.34
- Pressure Rating : Class 150
- Wall Thickness : ASME B16.34
- Face to Face : ASME B16.10
- Flanged Ends : ASME B16.5
- Inspection & Testing : API 598

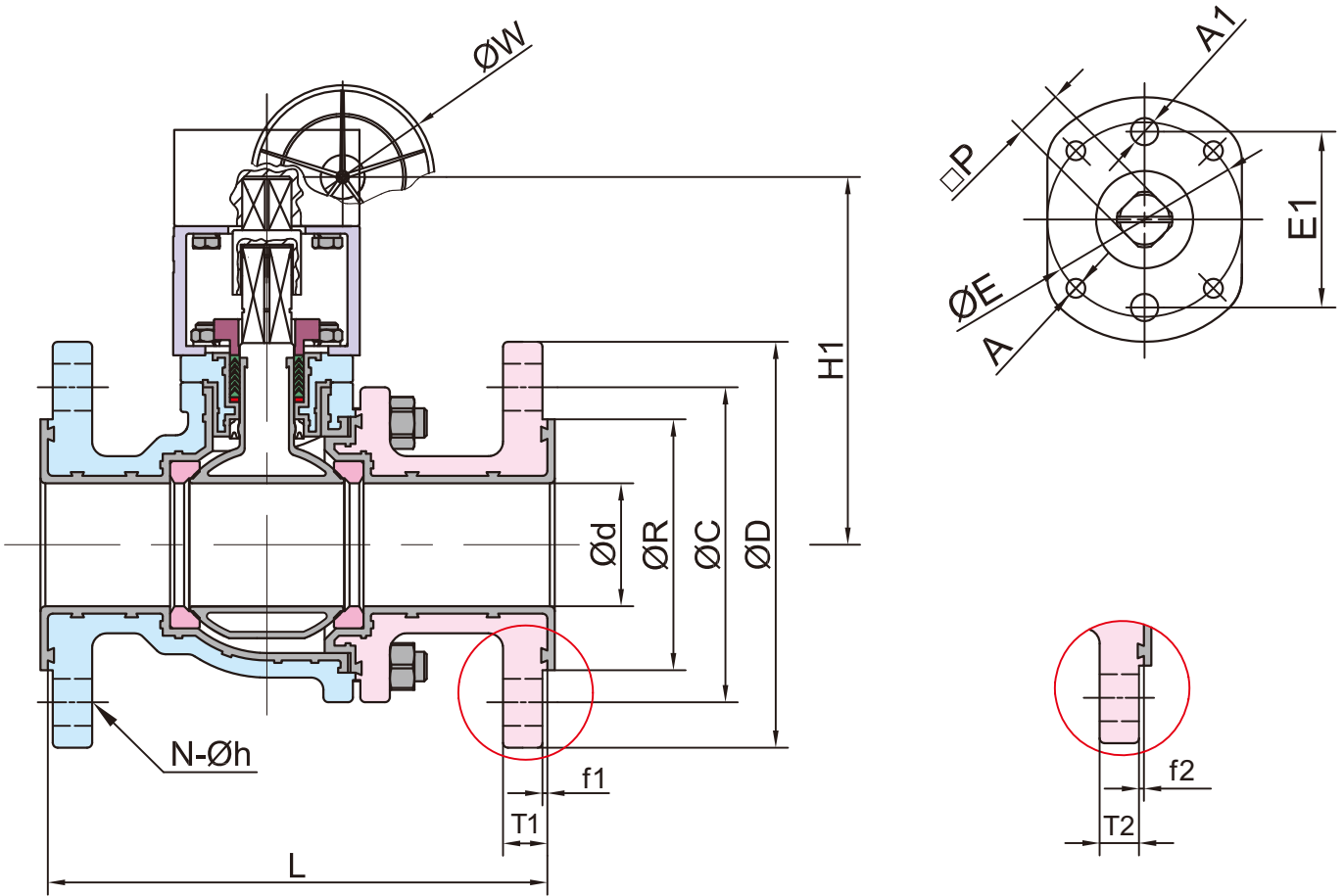

EN PN16

KV-N84K

Unit:mm

DN	d	R	C	D	L	T1	f1	N	h	H1	W	P	E	E1	A	A1	ISO5211
125	125	188	210	250	356	22	3	8	18	275	320	27	125	107	M12	M12	F12
150	151	212	240	285	394	22	3	8	22	325	360	36	140	120	M16	M12	F14

ASME Class 150

KV-N841

Unit:mm

NPS	d	R	C	D	L	T2	f2	N	h	H1	W	P	E	E1	A	A1	ISO5211
5	125	185.7	215.9	255	356	22.3	2	8	22.3	275	320	27	125	107	M12	M12	F12
6	151	215.9	241.3	280	394	23.9	2	8	22.3	325	360	36	140	120	M16	M12	F14

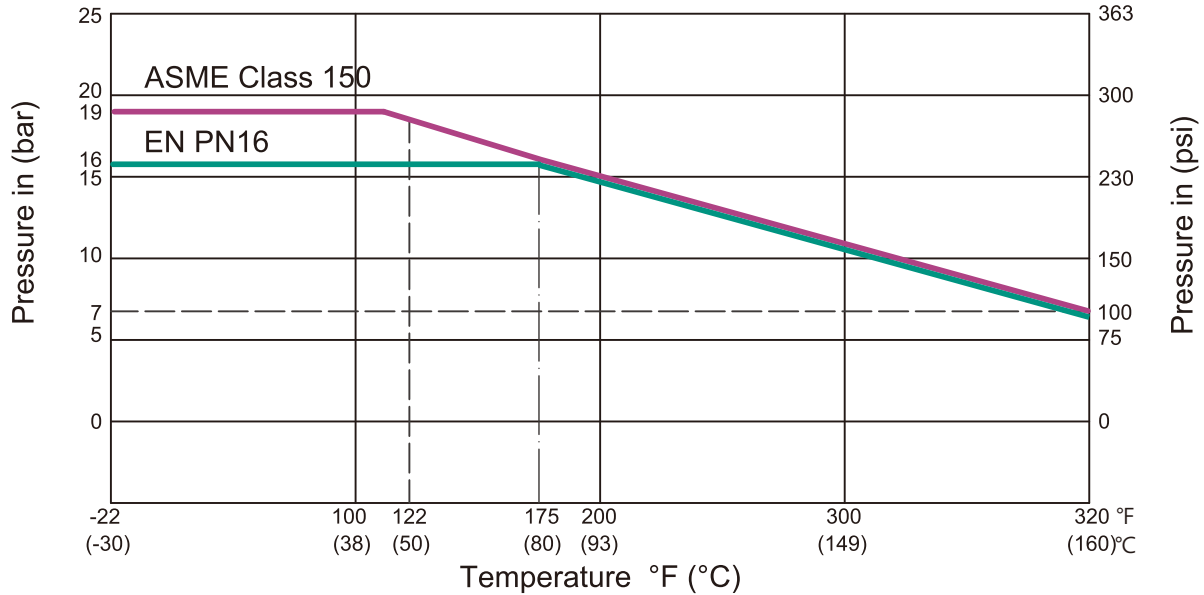

Cv Value

SIZE	NPS	1/2	3/4	1	1¼	1½	2	2½	3	4	5	6
	DN	15	20	25	32	40	50	65	80	100	125	150
Cv Value		30	55	96	170	270	470	780	1150	2100	3500	5000

Torque Figure

Close to Open Torque at Various Differential Pressure (ΔP), Standard Seats (PTFE / TFM1600)

Unit: N·m

SIZE	NPS		1/2	3/4	1	1¼	1½	2	2½	3	4	5	6
	DN		15	20	25	32	40	50	65	80	100	125	150
ΔP	5bar	N·m	6	8	12	16	20	30	60	70	100	210	300
	75psi	lb·in	53	71	106	142	177	266	531	620	885	1858	2655
	10bar	N·m	6	8	12	20	24	35	65	80	122	240	350
	150psi	lb·in	53	71	106	177	213	410	576	708	1080	2124	3097

Remarks :

- 1.The torque figures at 5 bar pressure are maximum values to be tested after the valves are placed for 24hours.
- 2.For actuator sizing, a safety factor of minimum 30% is recommended.

Headquarters (International Dept.)

14F-4, 120, Jhongjheng 1st Rd., Kaohsiung 80284, Taiwan
Tel: +886-7-7713121 Fax: +886-7-7235165
E-mail: sales@kifc.com

Zhongshan Factory

23-1, Nan-hou West Rd., Nan-tou Zhongshan City, Guangdong 528427, China
Tel: +86-760-23132179 23116839 Fax: +86-760-23110582

Fujian Factory

No. 1 Hengshan Industrial Road, Huangtian Town, Gutian County,
Fujian 352251, China
Tel: +86-593-3761598 Fax: +86-593-3762688

Vietnam Factory

Lot C-6A-CN, C-5A-CN, My Phuoc 2 Industrial Park, Ben Cat District,
Binh Duong Province, Vietnam
Tel: +84-2743-559866



KI-LBV 202207(1.5)
©2021 Kingdom Flow Control Co., Ltd.
All rights reserved.

The contents of this publication are presented for information purpose only, and while effort has been made to ensure their accuracy, they are not to be construed as warranties or guarantees, expressed or implied, regarding the products or services described herein or their use or applicability. All sales are governed by our terms and conditions. We reserve the right to modify or improve the designs or specifications of our products at any time without notice. Always verify that you have the most recent product specifications or other documentation prior to the installation of these products.